

TM 9-1290-263-34P

TECHNICAL MANUAL

DIRECT SUPPORT AND GENERAL SUPPORT

MAINTENANCE REPAIR PARTS AND

SPECIAL TOOLS LIST

(INCLUDING DEPOT MAINTENANCE REPAIR PARTS)

FOR

AZIMUTH INDICATOR:

M28A1 (1290-00-370-3486)

M28E2 (1290-00-370-3467)

8437917 (1290-00-168-5989)

8438753 (1290-00-168-5990)

HEADQUARTERS, DEPARTMENT OF THE ARMY

FEBRUARY 1985

Technical Manual
No. 9-1290-263-34P

HEADQUARTERS
DEPARTMENT OF THE ARMY
Washington, DC, 28 February 1985

ORGANIZATIONAL, DIRECT SUPPORT AND
GENERAL SUPPORT MAINTENANCE
REPAIR PARTS AND SPECIAL TOOLS LIST
(INCLUDING DEPOT MAINTENANCE REPAIR PARTS)

FOR

AZIMUTH INDICATOR:
M28A1 (1290-00-370-3486)
M28E2 (1290-00-370-3467)
8437917 (1290-00-168-5989),
8438753 (1290-00-168-5990)

Current as of 5 November 1984

REPORTING ERRORS AND RECOMMENDING IMPROVEMENTS

You can help improve this manual. If you find any mistakes or if you know of a way to improve the procedures, please let us know. Mail your letter, DA Form 2028 (Recommended Changes to Publications and Blank Forms), or DA Form 2028-2 located in back of this manual direct to: Commander, US Army Armament, Munitions and Chemical Command, ATTN: AMSMC-MAS, Rock Island, IL 61299-6000. A reply will be furnished to you.

TABLE OF CONTENTS

	Page	Illus/ Figure
Section I. INTRODUCTION	1	
Section II. REPAIR PARTS LIST	1-1	
Group 00 Azimuth Indicator M28A1 7970854-1 (partial view - upper section)	1-1	1
Azimuth Indicator M28E2 10933520-1, 8437917, 8438753 (partial view - upper section)	2-1	2
Azimuth Indicator M28A1 7970854-1, M28E2 10933520-1 (partial view - lower section)	3-1	3

*This manual, together with TM 9-1290-263-34, 28 February 1985, supersedes TM 9-1290-263-34, 6 April 1971, including all changes.

TABLE OF CONTENTS--Continued

	Page	Illus/ Figure
Section II. REPAIR PARTS LIST--Continued		
Group 00 Azimuth Indicator 8437917 (partial view - upper section)	4-1	4
Azimuth Indicator 8437917 (partial view - lower section)	5-1	5
Azimuth Indicator 8438753 (partial view - rear section)	6-1	6
Azimuth Indicator 8438753 (partial view - lower section)	7-1	7
Section III. SPECIAL TOOLS LIST (not applicable) ...	8-1	
Section IV. NATIONAL STOCK NUMBER AND PART NUMBER INDEX	I-1	

ORGANIZATIONAL, DIRECT SUPPORT, AND
GENERAL SUPPORT MAINTENANCE
REPAIR PARTS AND SPECIAL TOOLS LIST
(INCLUDING DEPOT MAINTENANCE REPAIR PARTS)

SECTION I. INTRODUCTION

1. Scope. This RPSTL lists and authorizes spares and repair parts; special tools; special test, measurement and diagnostic equipment (TMDE); and other special support equipment required for performance of organizational, direct support, and general support maintenance of the azimuth indicator. It authorizes the requisitioning, issue, and disposition of spares, repair parts and special tools as indicated by the Source, Maintenance and Recoverability (SMR) codes.

2. General. In addition to this section, Introduction, this Repair Parts and Special Tools List is divided into the following sections:

a. Section II. Repair Parts List. A list of spares and repair parts authorized by this RPSTL for use in the performance of maintenance. The list also includes parts which must be removed for replacement of the authorized parts. Parts lists are composed of functional groups in ascending alphanumeric sequence, with the parts in each group listed in ascending figure and item number sequence. Bulk materials are listed in item name sequence. Repair parts kits are listed separately in their own functional group within Section II. Repair parts for repairable special tools are also listed in this section. Items listed are shown on the associated illustration(s)/figure(s).

b. Section III. Special Tools List. A list of special tools, special TMDE, and other special support equipment authorized by this RPSTL (as indicated by Basis of Issue (BOI) information in DESCRIPTION AND USABLE ON CODE column) for the performance of maintenance.

c. Section IV. National Stock Number and Part Number Index. A list, in National Item Identification Number (NIIN) sequence, of all National stock numbered items appearing in the listing, followed by a list in alphanumeric sequence of all part numbers appearing in the listing. National stock numbers and part numbers are cross-referenced to each illustration figure and item number appearance.

3. Explanation of Columns (Section II and III).

a. ITEM NO. (Column (1)). Indicates the number used to identify items called out in the illustration.

b. SMR CODE (Column (2)). The Source, Maintenance, and Recoverability (SMR) Code is a 5-position code containing supply/requisitioning information, maintenance category authorization criteria, and disposition instruction, as shown in the following breakout:

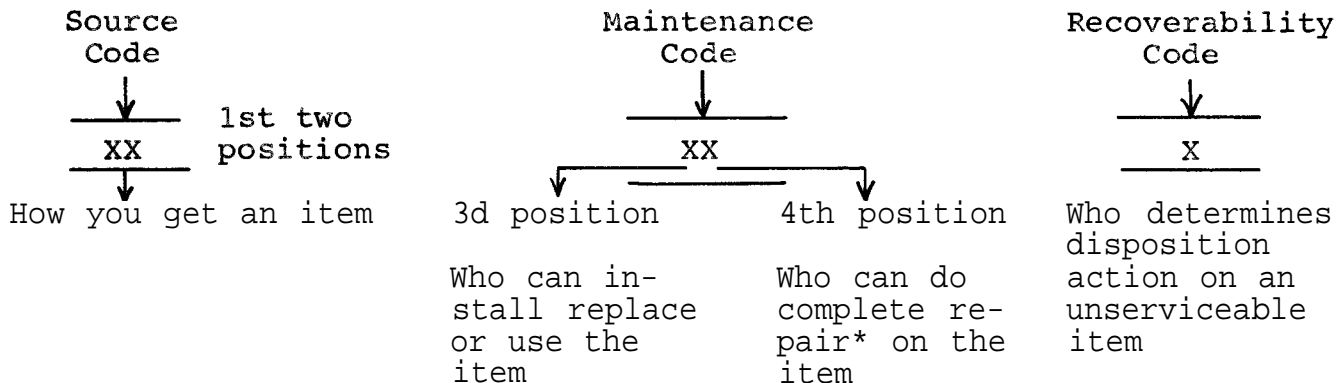

*Complete Repair: Maintenance capacity, capability, and authority to perform all corrective maintenance tasks of the "Repair" function in a use/user environment in order to restore serviceability to a failed item.

(1) Source Code. The source code tells you how to get an item needed for maintenance, repair, or overhaul of an end item/equipment. Explanations of source codes follows:

Code	Explanation
<p>PA PB PC** PD PE PF PG</p>	<p>Stocked items; use the applicable NSN to request/requisition items with these source codes. They are authorized to the category indicated by the code entered in the 3d position of the SMR codes.</p> <p>**NOTE: Items coded PC are subject to deterioration.</p>
<p>KD KF KB</p>	<p>Items with these codes are not to be requested/requisitioned individually. They are part of a kit which is authorized to the maintenance category indicated in the 3d position of the SMR code. The complete kit must be requisitioned and applied.</p>
<p>MO - (Made at org/ AVUM Level) MF - (Made at DS/ AVIM Level) MH - (Made at GS Level) ML - (Made at Spe- cialized Repair Act (SRA)) MD - (Made at Depot)</p>	<p>Items with these codes are not to be requested/requisitioned individually. They must be made from bulk material which is identified by the part number in the DESCRIPTION AND USABLE ON CODE (UOC) column and listed in the Bulk Material Group of the repair parts list in this RPSTL. If the item is authorized to you by the 3d position code of the SMR Code, but the source code indicates it is made at a higher level, order the item from the higher level of maintenance.</p>

Code	Explanation
AO - (Assembled by org/AVUM Level)	Items with these codes are not to be requested/requisitioned individually. The parts that make up the assembled item must be requisitioned or fabricated and assembled at the level of maintenance indicated by the source code. If the 3d position code of the SMR code authorizes you to replace the item, but the source code indicates the item is assembled at a higher level, order the item from the higher level of maintenance.
AF - (Assembled by DS/AVIM Level)	
AH - (Assembled by GS Category)	
AL - (Assembled by SRA)	
AD - (Assembled by Depot)	

- XA - Do not requisition an "XA" - coded item. Order its next higher assembly. (Also, refer to the NOTE below.)
- XB - If an "XB" item is not available from salvage, order it using the FSCM and part number given.
- XC - Installation drawing, diagram, instruction sheet, field service drawing, that is identified by manufacturer's part number.
- XD - Item is not stocked. Order an "XD" - coded item through normal supply channels using the FSCM and part number given, if no NSN is available.

NOTE : Cannibalization or controlled exchange, when authorized, may be used as a source of supply for items with the above source codes, except for those source coded "XA" or those aircraft support items restricted by requirements of AR 700-42.

(2) Maintenance Code. Maintenance codes tell you the level(s) of maintenance authorized to USE and REPAIR support items. The maintenance codes are entered in the third and fourth positions of the SMR Code as follows:

(a) The maintenance code entered in the third position tells you the lowest maintenance level authorized to remove, replace, and use an item. The maintenance code entered in the third position will indicate authorization to one of the following levels of maintenance.

Code	Application/Explanation
C	Crew or operator maintenance done within organizational or aviation unit maintenance.
O	Organizational or aviation unit category can remove, replace, and use the item.
F	Direct support or aviation intermediate level can remove, replace, and use the item.
H	General support level can remove, replace, and use the item.

Code	Application/Explanation
L	Specialized repair activity can remove, replace, and use the item.
D	Depot level can remove, replace, and use the item.

(b) The maintenance code entered in the fourth position tells whether or not the item is to be repaired and identifies the lowest maintenance level with the capability to do complete repair (i.e., perform all authorized repair functions). (NOTE: Some limited repair may be done on the item at a lower level of maintenance, if authorized by the Maintenance Allocation Chart (MAC) and SMR codes.) This position will contain one of the following maintenance codes.

Code	Application/Explanation
O	Organizational or aviation unit is the lowest level that can do complete repair of the item.
F	Direct support or aviation intermediate is the lowest level that can do complete repair of the item.
H	General support is the lowest level that can do complete repair of the item.
L	Specialized repair activity () is the lowest level that can do complete repair of the item.
D	Depot is the lowest level that can do complete repair of the item.
Z	Nonreparable. No repair is authorized.
B	No repair is authorized. (No parts or special tools are authorized for the maintenance of a "B" coded item.) However, the item may be reconditioned by adjusting, lubricating, etc. , at the user level.

(3) Recoverability Code. Recoverability codes are assigned to items to indicate the disposition action on unserviceable items. The recoverability code is entered in the fifth position of the SMR Code as follows:

Recoverability Codes	Application/Explanation
Z	Nonreparable item. When unserviceable, condemn and dispose of the item at the level of maintenance shown in 3d position of SMR Code.

Recoverability Codes	Application/Explanation
O	Reparable item. When uneconomically reparable, condemn and dispose of the item at organizational or aviation unit level.
F	Reparable item. When uneconomically reparable, condemn and dispose of the item at direct support or aviation intermediate level.
H	Reparable item. When uneconomically reparable condemn and dispose of the item at the general support level.
D	Reparable item. When beyond lower level repair capability, return to depot. Condemnation and disposal of item not authorized below depot level.
L	Reparable item. Condemnation and disposal not authorized below Specialized Repair Activity (SRA).
A	Item requires special handling or condemnation procedures because of specific reasons (e.g. , precious metal content, high dollar value, critical material). Refer to appropriate manuals/directives for specific instructions.

c. FSCM (Column (3)). The Federal Supply Code for Manufacturer (FSCM) is a 5-digit numeric code which is used to identify the manufacturer, distributor, or Government agency, etc., that supplies the item .

d. PART NUMBER (Column (4)). Indicates the primary number used by the manufacturer (individual, company, firm, corporation, or Government activity) , which controls the design and characteristics of the item by means of its engineering drawings, specifications standards, and inspection requirements to identify an item or range of items.

NOTE : When you use an NSN to requisition an item, the item you receive may have a different part number from the part ordered.

e. DESCRIPTION AND USABLE ON CODE (UOC) (Column (5)). This column includes the following information:

(1) The Federal item name and, when required, a minimum description to identify the item.

(2) When the item is not used with all serial numbers of the same model, the effective serial numbers are shown on the last line(s) of the description (before UOC).

(3) The usable on code, when applicable (see paragraph 5, Special information).

(4) The statement "END OF FIGURE" appears just below the last item description in Column 5 for a given figure in both Section II and Section III.

f. QTY (Column (6)). The QTY (quantity per figure column) indicates the quantity of the item used in the breakout shown on the illustration figure, which is prepared, for a functional group, sub-functional group, or an assembly. A "V" appearing in this column in lieu of a quantity indicates that the quantity is variable and the quantity may vary from application to application.

4. Explanation of Columns (Sect. IV).

a. NATIONAL STOCK NUMBER (NSN) INDEX.

(1) STOCK NUMBER column. This column lists the NSN by National Item Identification Number (NIIN) sequence. The NIIN consists of the last nine NSN digits of the NSN (i.e., 5305-01-674-1467). When using this column to locate an item, ignore the first 4 digits of the NSN. However, the complete NSN should be used when ordering items by stock number.

(2) FIG. column. This column lists the number of the figure where the item is identified/located. The figures are in numerical order in Section II and Section III.

(3) ITEM column. The item number identifies the item associated with the figure listed in the adjacent FIG. column. This item is also identified by the NSN listed on the same line.

b. PART NUMBER INDEX. Part numbers in this index are listed by part number in ascending alphanumeric sequence (i.e., vertical arrangement of letter and number combination which places the first letter or digit of each group in order A through Z, followed by the numbers 0 through 9 and each following letter or digit in like order).

(1) FSCM column. The Federal Supply Code for Manufacturer (FSCM) is a 5-digit numeric code used to identify the manufacturer, distributor, or Government agency, etc., that supplies the item.

(2) PART NUMBER column. Indicates the primary number used by the manufacturer (individual, firm, corporation, or Government activity), which controls the design and characteristics of the item by means of its engineering drawings, specifications standards, and inspection requirements to identify an item or range of items.

(3) STOCK NUMBER column. This column lists the NSN for the associated part number and manufacturer identified in the PART NUMBER and FSCM columns to the left.

(4) FIG. column. This column lists the number of the figure where the item is identified/located in Section II and III.

(5) ITEM column. The item number is that number assigned to the item as it appears in the figure referenced in the adjacent figure number column.

5. Special Information.

a. USABLE ON CODE. The usable on code appears in the lower left corner of the Description column heading. Usable on codes are shown as "UOC:" in the Description column (justified left) on the first line applicable item description/nomenclature. Uncoded items are applicable to all models. Identification of the usable on codes used in the RPSTL are:

<u>Code</u>	<u>Used On</u>
F25	Indicator, Azimuth, M28A1
F26	Indicator, Azimuth, M28E2
338	Indicator, Azimuth, 8438753
324	Indicator, Azimuth, 8437917

b. ASSOCIATED PUBLICATIONS. The publication(s) listed below pertain to the azimuth indicator and its components.

<u>Publication</u>	<u>Short Title</u>
TM 9-1290-263-34	Azimuth Indicator M28A1, M28E2, 8437917, and 8438753

6. How to Locate Repair Parts.

a. When National Stock Number or Part Number is Not Known.

(1) First. Using the table of contents, determine the assembly group or subassembly group to which the item belongs. This is necessary since figures are prepared for assembly groups and subassembly groups, and listings are divided into the same groups.

(2) Second. Find the figure covering the assembly group or subassembly group to which the item belongs.

(3) Third. Identify the item on the figure and note the item number.

(4) Fourth. Refer to the Repair Parts List for the figure to find the part number for the item number noted on the figure.

(5) Fifth. Refer to the Part Number Index to find the NSN, if assigned.

b. When National Stock Number or Part Number is Known.

(1) First. Using the Index of National Stock Numbers and Part numbers, find the pertinent National Stock Number or Part Number. The NSN index is in National Item Identification Number (NIIN) sequence (see 4.1(1)). The part numbers in the Part Number index are listed in ascending alphanumeric sequence (see 4.b). Both indexes cross-reference you to the illustration figure and item number of the item you are looking for.

(2) Second. After finding the figure and item number, verify that the item is the one you're looking for, then locate the item number in the repair parts list for the figure.

7. Abbreviations. Not applicable.

SECTION II

TM9-1290-263-34P

(1) ITEM NO	(2) SMR CODE	(3) FSCM	(4) PART NUMBER	(5) DESCRIPTION AND USABLE ON CODE (UOC)	(6) QTY
FIGURE 1, GROUP 00 AZIMUTH INDICATOR					
M28A1 7970854-1					
(PARTIAL VIEW-UPPER SECTION)					
1	PAOZZ	19200	6578454	LIGHT, INSTRUMENT UOC:F25	1
2	PAFZZ	88044	AN500D5-3	SCREW, MACHINE UOC: F25	5
3	PAFZZ	19200	7068071	DIAL, CONTROL UOC:F25	1
4	PAFZZ	19200	7068048	CLIP, SPRING TENSION UOC:F25	1
5	PAFZZ	96906	MS51964-51	SETSCREW UOC:F25	6
6	PAFZZ	19200	7068069	CLAMP UOC:F25	1
7	PAFZZ	96906	MS35206-245	SCREW, MACHINE UOC:F25	4
8	PAFZZ	19200	5345713	KNOB UOC:F25	1
9	PAFZZ	19200	7068070	GASKET UOC:F25	
10	PAFZZ	19207	7970862	WASHER UOC:F25	1
11	PAFZZ	96906	MS35671-36	PIN, GROOVED, HEADLES HEADLESS UOC:F25	1
12	PAFZZ	19207	7970867	CONE, DRILLED UOC:F25	1
13	PAFZZ	19207	7970855	RE SETTER ASSY UOC:F25	1
14	PAFZZ	19207	7970865	SPRING UOC:F25	1
15	PAFZZ	19207	7970858	FLANGE UOC:F25	1
16	PAFZZ	19200	7068074	RING, BELLOWS, STOP UOC:F25	1
17	PAFZZ	19207	7069656	GASKET UOC:F25	1
18	PAFZZ	96906	MS35206-208	SCREW, MACHINE UOC:F25	4
19	PAFZZ	19207	11655096	RING, INDICATOR A21M UOC:F25	1
20	PAFZZ	19200	8734407	BELLOWS UOC:F25	1
21	PAFZZ	19207	10905849	GASKET UOC:F25	1
22	PAFZZ	19200	7068064	WINDOW, DIAL UOC:F25	1
23	PAFZZ	19207	11653615	POINTER ASSEMBLY UOC:F25	1

SECTION II

TM9-1290-263-34P

(1) ITEM NO	(2) SMR CODE	(3) FSCM	(4) PART NUMBER	(5) DESCRIPTION AND USABLE ON CODE (UOC)	(6) QTY
24	PAFZZ	96906	MS35190-250	SCREW, MACHINE UOC:F25	4
25	PAFZZ	19200	7068060	FLANGE UOC:F25	1
26	PAFZZ	19207	11653613	POINTER, DIAL UOC:F25	1
27	PAFZZ	19200	5345718	WASHER, SPLIT UOC:F25	1
28	PAFZZ	43334	SSR6X3A	BEARING, BALL, ANNULA ANNULAR UOC:F25	1
29	PAFZZ	19207	11653614	POINTER, DIAL UOC:F25	1
30	PAFZZ	19200	5345723	SPRING, HELICAL, COMP UOC:F25	1
31	XBFZZ	19207	5345720	SPACER, SLEEVE UOC:F25	1
32	PAFZZ	24446	N81P9024C13	SCREW, MACHINE UOC:F25	4
33	PAFZZ	19200	7028399	DIAL UOC:F25	1
34	PAFZZ	19200	5345922	FELT, MECHANICAL, PRE UOC:F25	1
35	PAFZZ	19200	5345924	SPACER, RING UOC:F25	1
36	PAFZZ	96906	MS21318-21	SCREW, DRIVE UOC:F25	4
37	PADZZ	19200	7972103	PLATE, IDENTIFICATIO UOC:F25	1
38	PAOZZ	81348	W-L-00111/10	LAMP, INCANDESCENT UOC:F25	2
39	PAFZZ	96906	MS35333-37	WASHER, LOCK UOC:F25	2
40	PAFZZ	19207	6209551	LAMPHOLDER UOC:F25	2
41	PAFZZ	96906	MS35206-243	SCREW, MACHINE UOC:F25	1
42	PAFZZ	96906	MS35333-38	WASHER, LOCK UOC:F25	1
43	PAFZZ	21450	506202	TERMINAL, LUG UOC:F25	2
44	PAFZZ	96906	MS35763-404	BOLT, SELF-LOCKING UOC:F25	4
45	PAFZZ	19200	5345719	GASKET UOC:F25	1
46	PAFZZ	96906	MS35214-38	SCREW, MACHINE UOC:F25	2
47	XBFZZ	19200	5383779	CLIP UOC:F25	1
48	PAFZZ	19207	7089292	INSULATOR, SLEEVE UOC:F25	1
49	PAFZZ	19200	5320625	PLUG UOC:F25	1

SECTION II

TM9-1290-263-34P

(1) ITEM NO	(2) SMR CODE	(3) FSCM	(4) PART NUMBER	(5) DESCRIPTION AND USABLE ON CODE (UOC)	(6) QTY
50	XADZZ	19207	7970866	HOUSING UOC:F25	1

END OF FIGURE

Section II REPAIR PARTS LIST

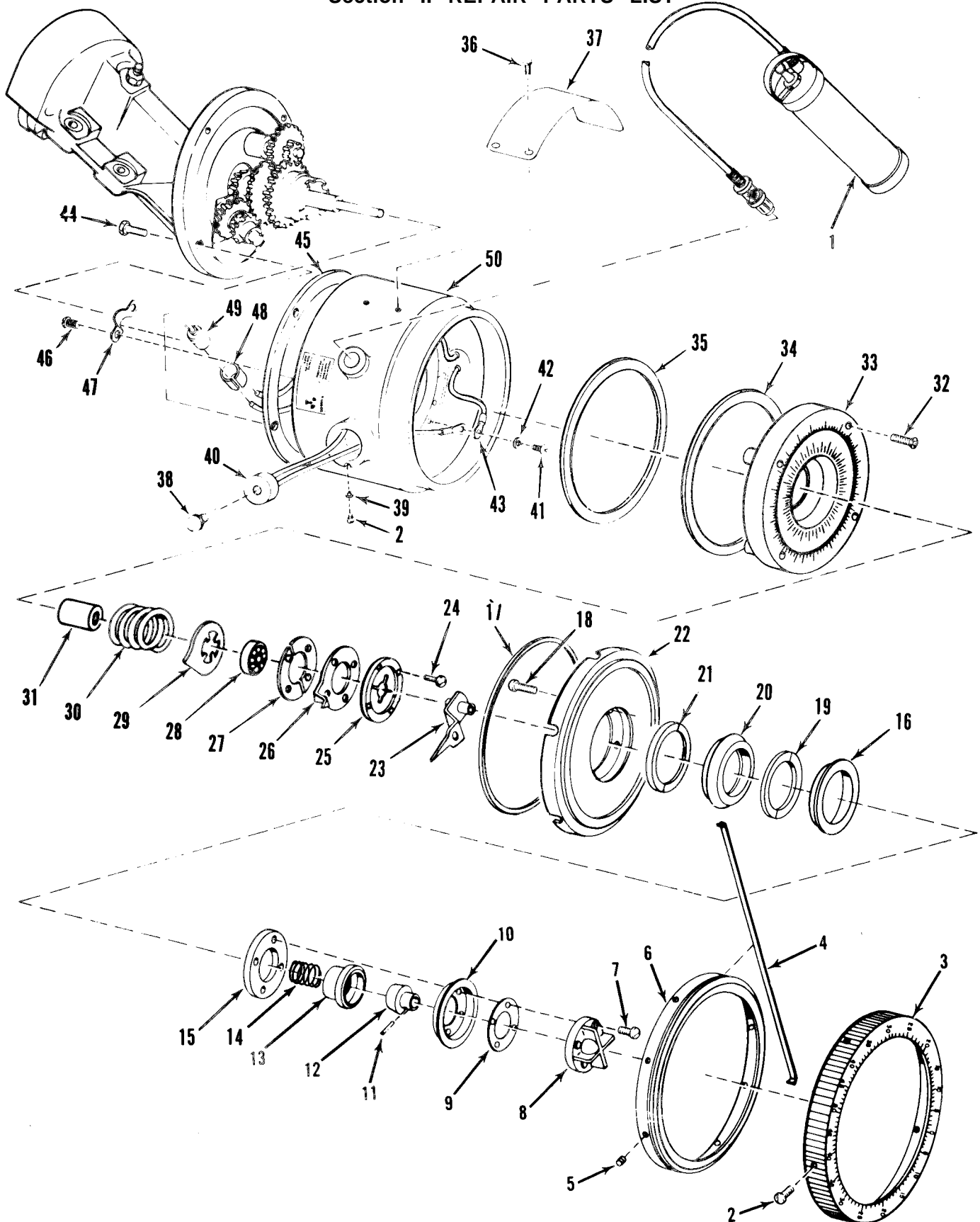

Figure 1. Azimuth indicator M28A17970854-1 (partial view-upper section)

SECTION II

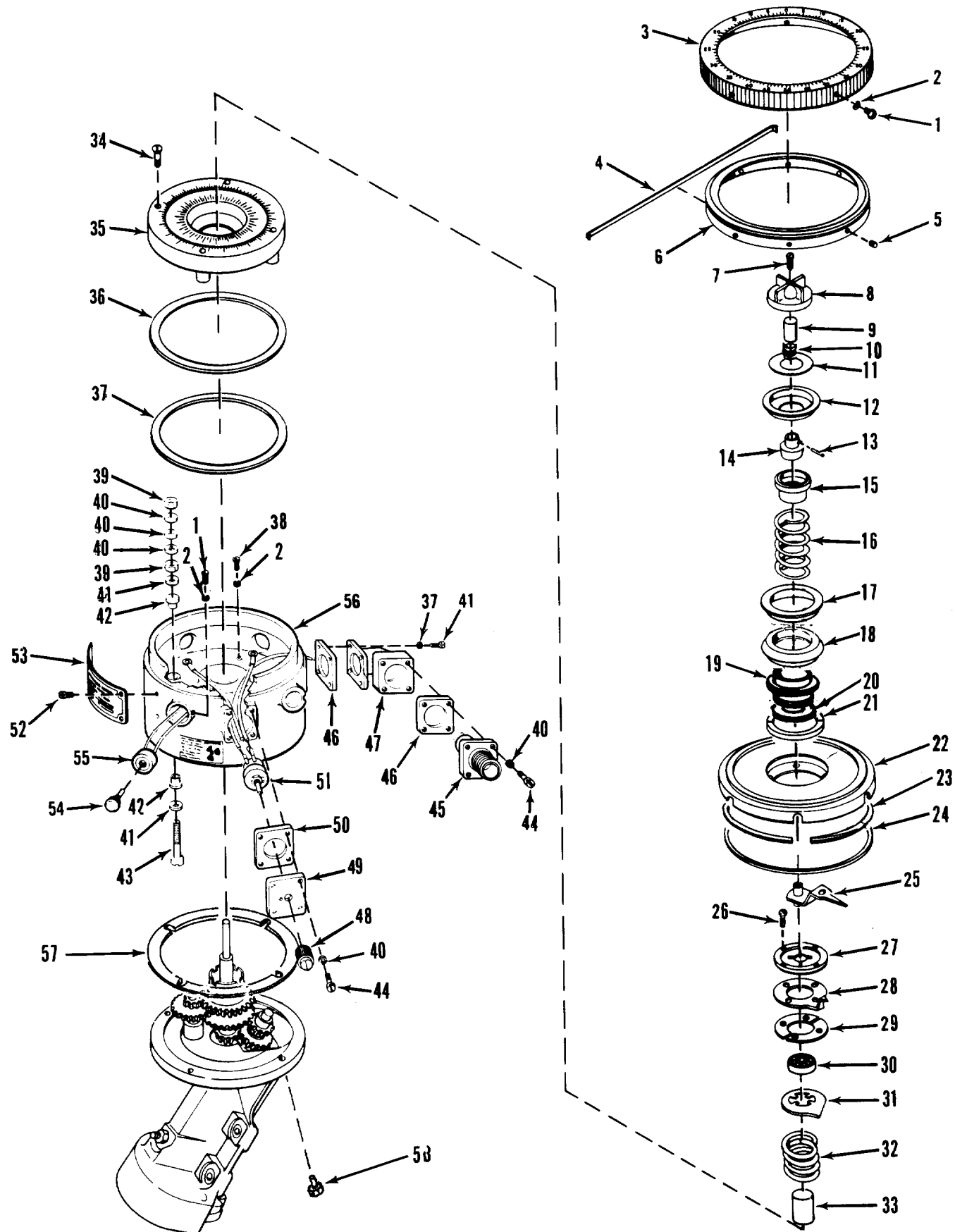

Figure 2. Azimuth indicator M28E2 10933520-1, 8437917, 84338753
(partial view-upper section)

SECTION II

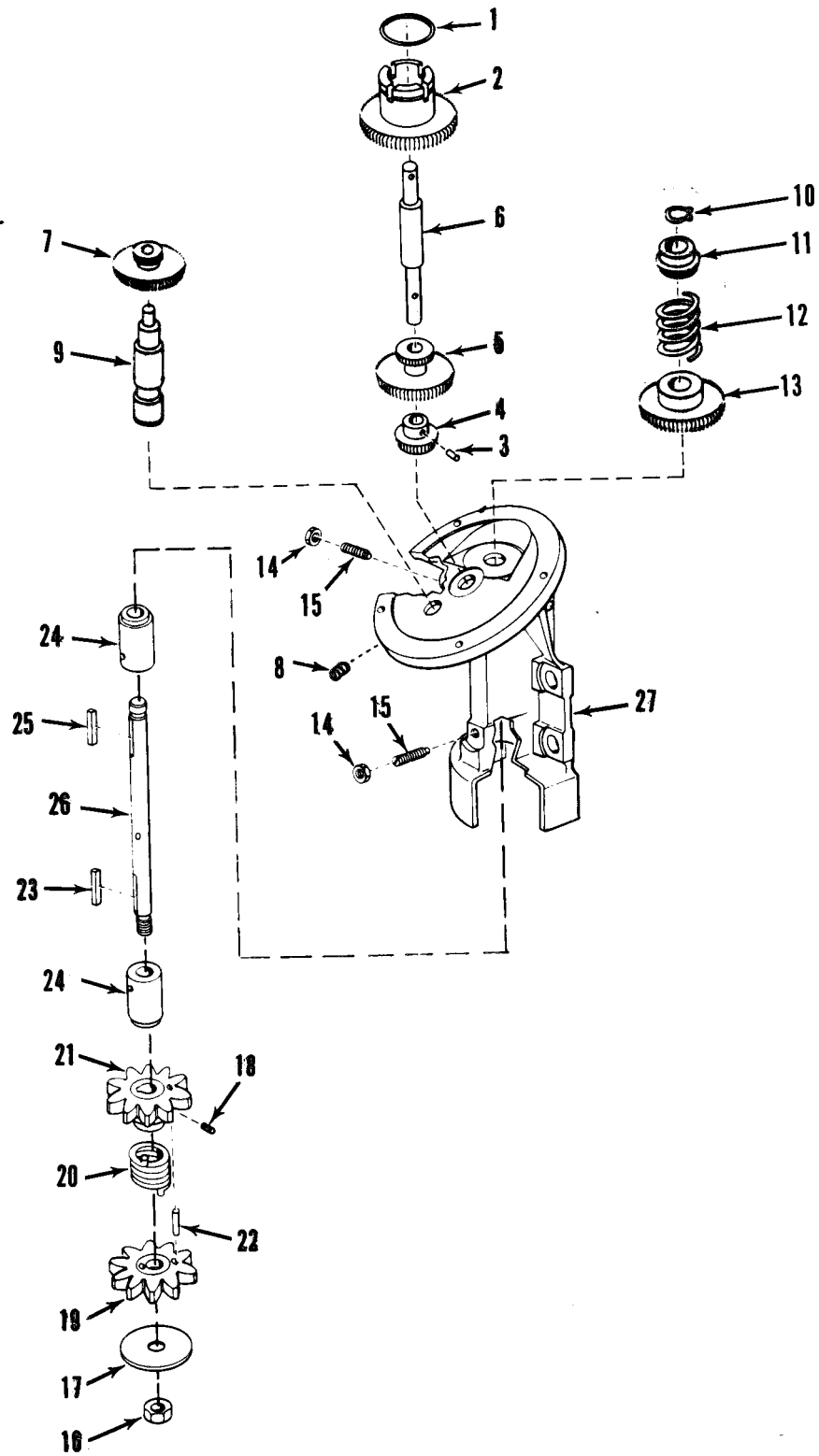

Figure 3. Azimuth indicator M28A1 7970854-1, M28E2 10933520-1 (partial view-lower section)

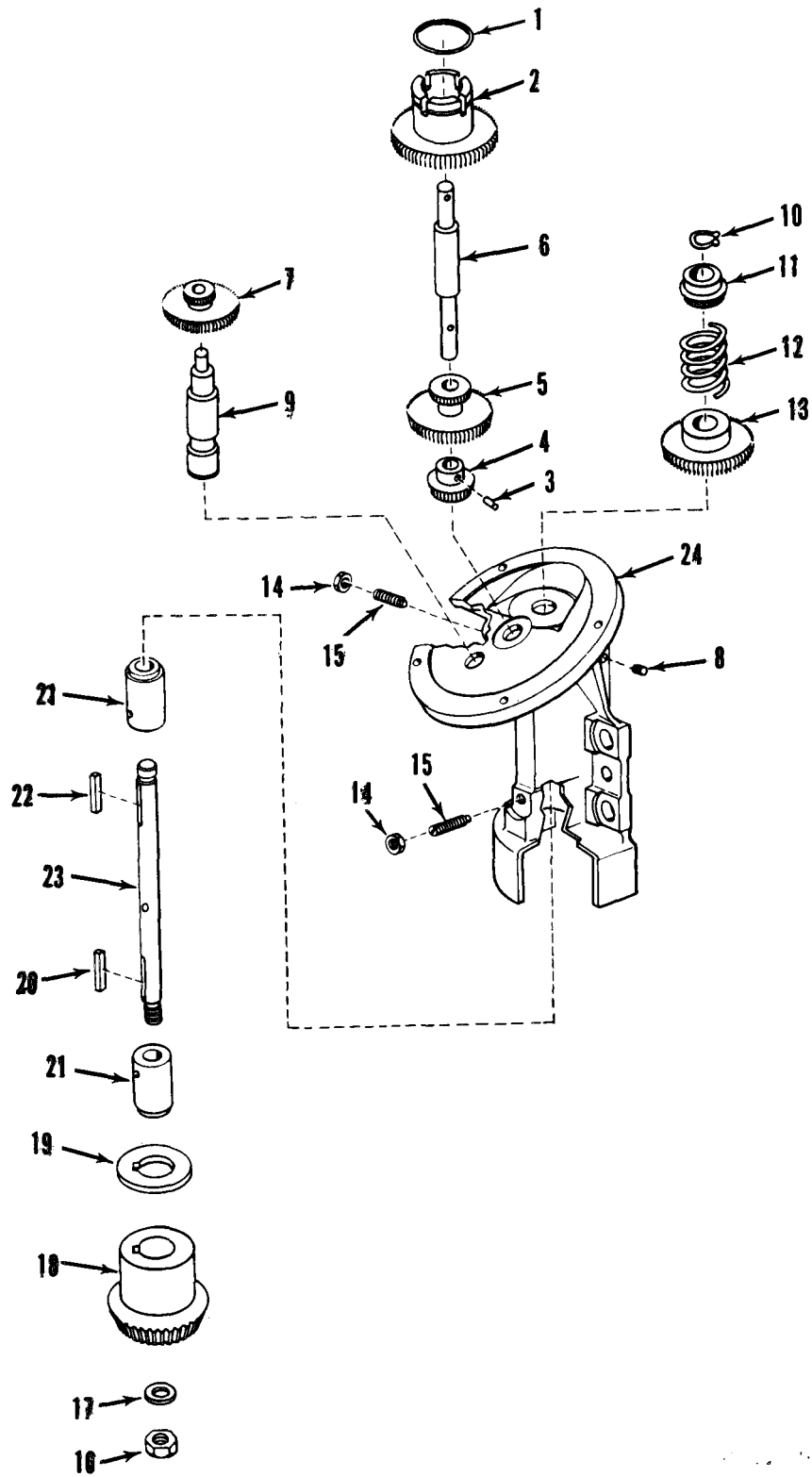

Figure 4. Azimuth indicator 8437917 (partial view-upper section)

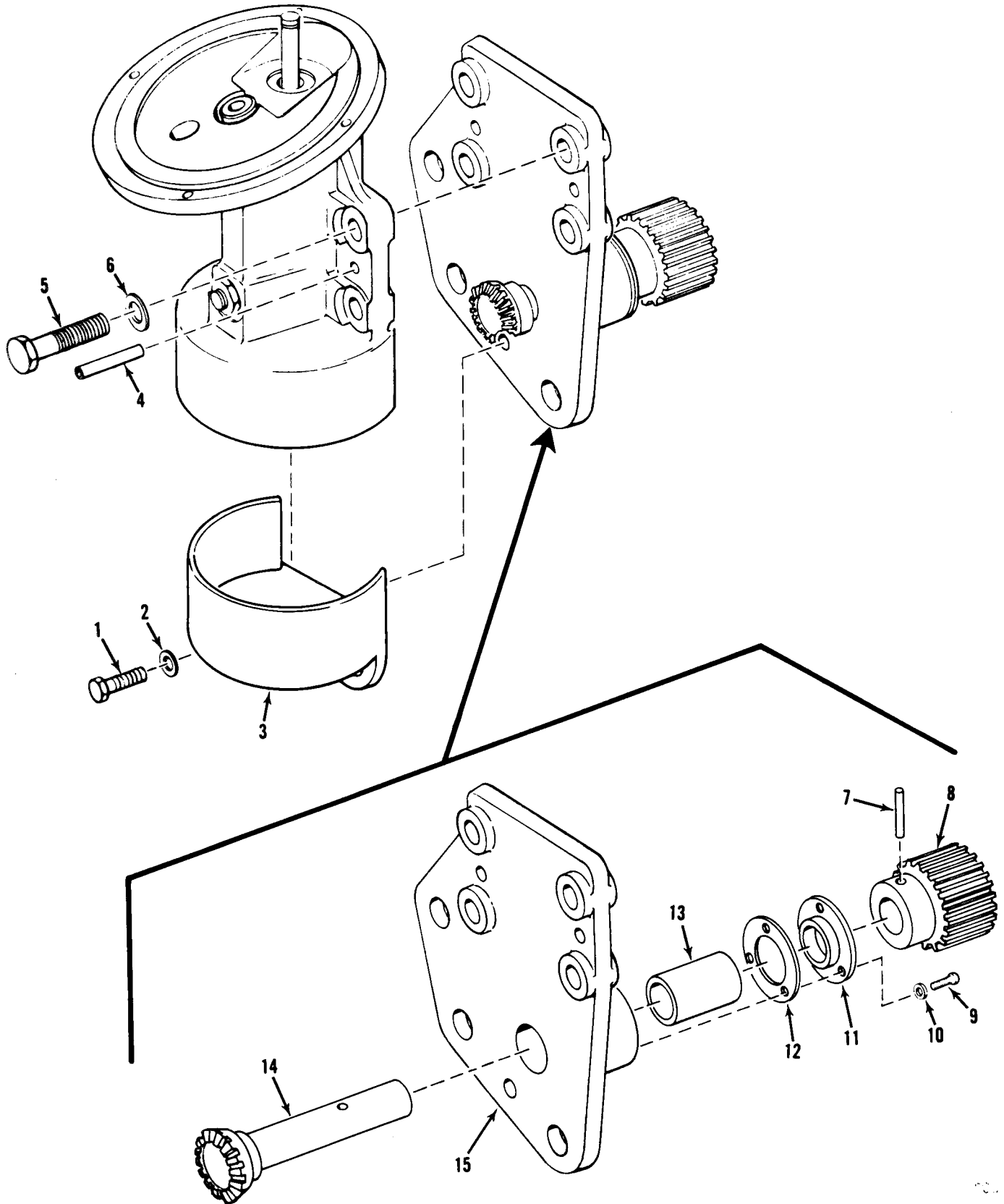

Figure 5. Azimuth indicator 8437917 (partial view-lower section)

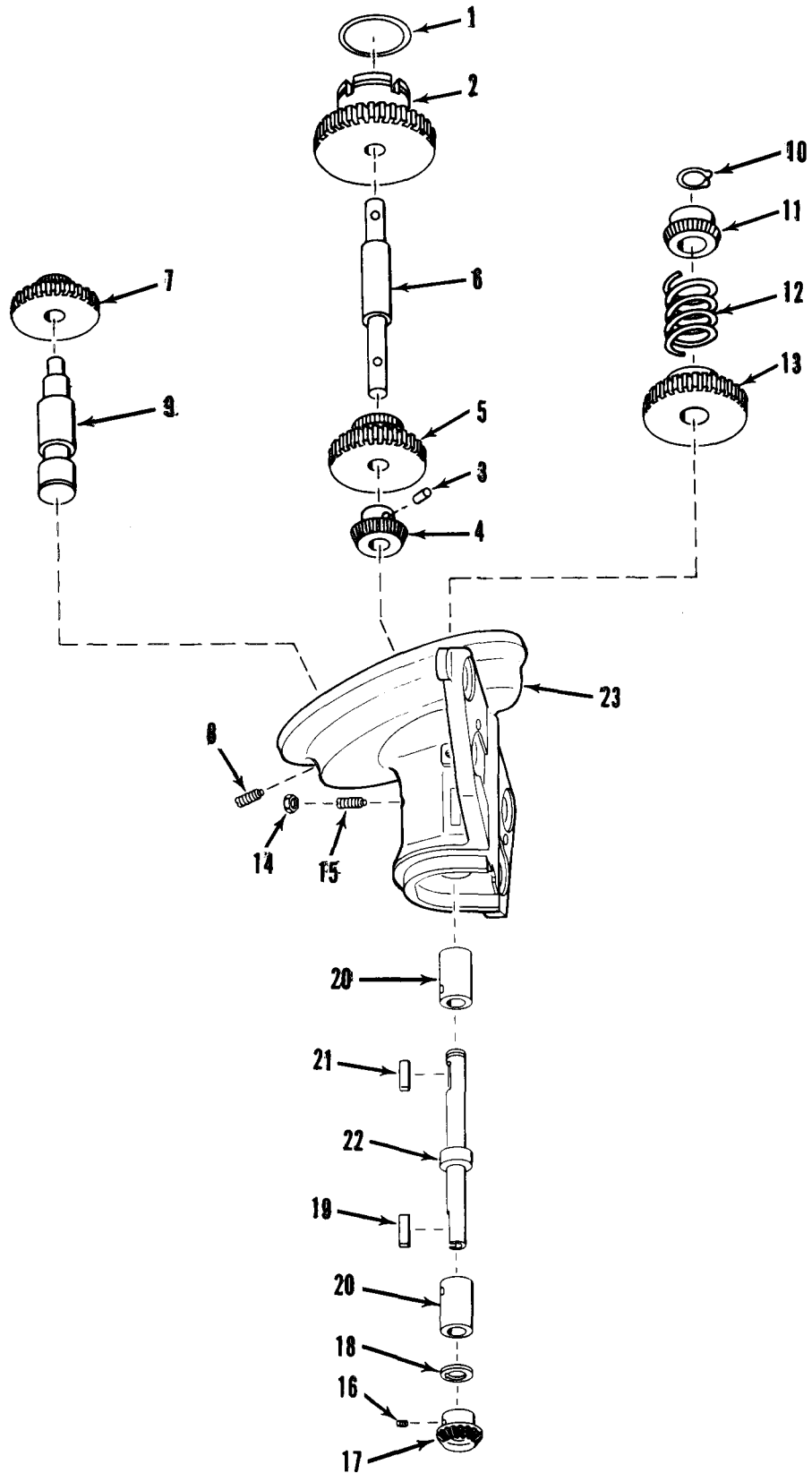

Figure 6. Azimuth indicator 8438753 (partial view-rear section)

NATIONAL STOCK NUMBER AND PART NUMBER INDEX

FSCM	PART NUMBER	PART NUMBER INDEX	
		STOCK NUMBER	FIG. ITEM
19204	8437929	5315-01-134-8862	6 3
19204	8437938	9905-01-105-5361	2 53
19204	8438158	3020-00-116-3380	7 15
19204	8438159	3020-00-238-5353	7 7
19204	8438737	9905-01-124-2504	2 53
19200	8438738		6 23
19200	8438741		7 23
19200	8438742	1290-01-124-2513	6 22
			7 14
19204	8438744	3020-00-419-8704	7 16
19204	8438745	3020-00-419-8714	6 17
19200	8438748	1290-01-124-2514	6 6
19200	8438749		7 20
19204	8438751	5305-01-122-9896	6 15
19200	8438752		7 5
19204	8438754	5365-01-130-2046	7 11
19204	8438755	1290-00-407-7020	7 10
19204	8438756	1290-00-407-7019	6 20
19200	8438761-1		4 19
			6 18
19200	8447291		2 56
19204	8447532	5360-00-151-5969	2 32
19204	8447533	5355-00-418-8402	2 35
19200	8447535		4 24
19200	8734407	1260-00-346-8644	1 20

SECTION II

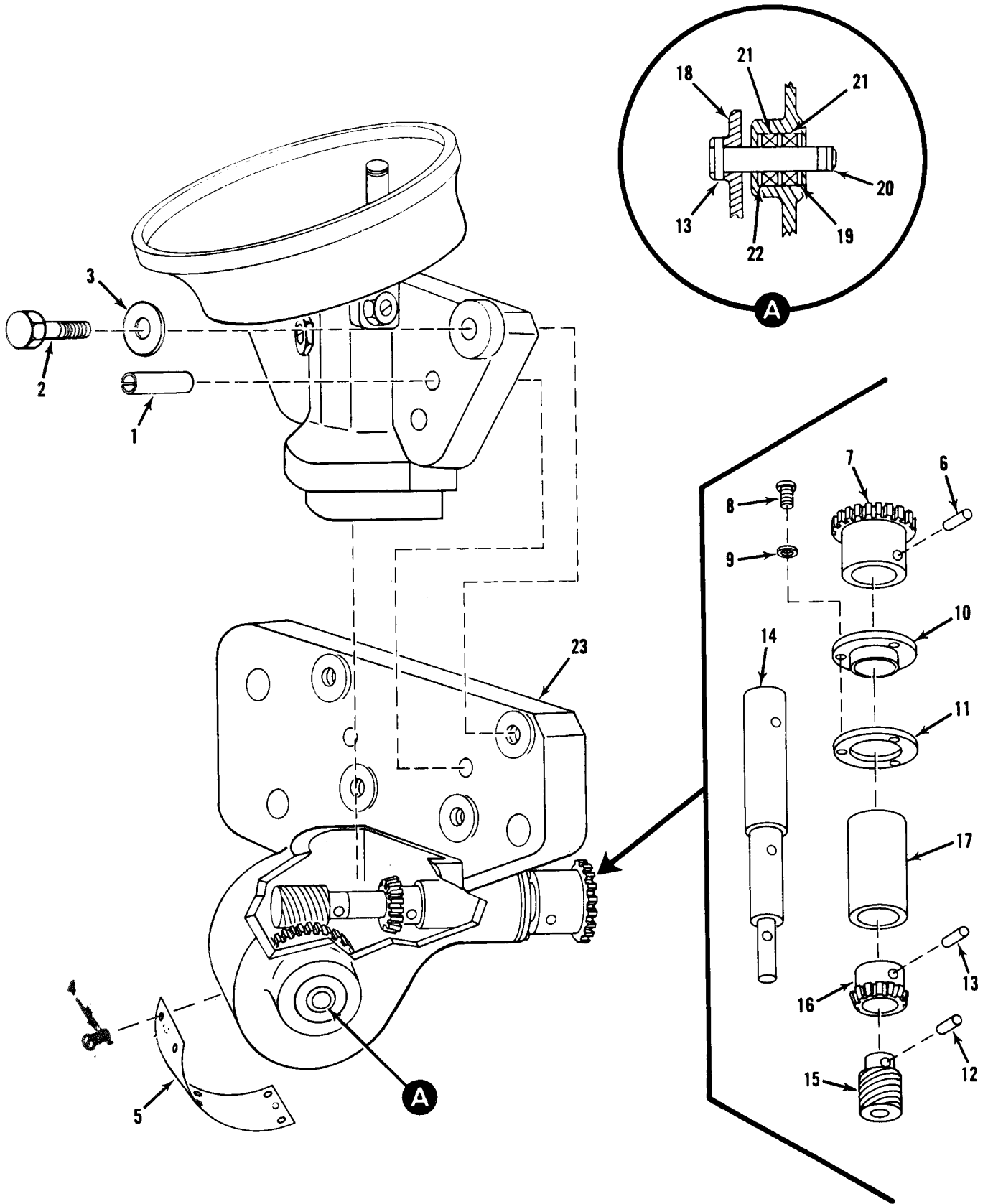

Figure 7. Azimuth indicator 8438753 (partial view-lower section)

NATIONAL STOCK NUMBER AND PART NUMBER INDEX

NATIONAL STOCK NUMBER INDEX					
STOCK NUMBER	FIG.	ITEM	STOCK NUMBER	FIG.	ITEM
5315-00-014-2959	3	3	1240-00-346-8249	1	15
5315-00-044-4258	6	21	1240-00-346-8250	3	7
5940-00-050-6202	1	43		4	7
6240-00-051-4843	2	54		6	7
5305-00-052-6883	2	26	1240-00-346-8252	1	12
5305-00-054-5649	5	9		2	14
	7	8	1240-00-346-8253	3	6
5315-00-058-9784	7	6		4	6
5315-00-058-9808	5	4	1260-00-346-8644	1	20
	7	1	5305-00-407-4122	2	5
5305-00-059-8263	1	46	1290-00-407-7019	6	20
5310-00-082-1404	2	41	1290-00-407-7020	7	10
1290-00-100-4144	2	9	1290-00-407-7021	5	11
1290-00-100-4145	1	19	3020-00-409-8783	4	18
	2	23	5355-00-418-8402	2	35
1290-00-100-4248	2	19	3020-00-419-8704	7	16
5360-00-111-1683	2	16	3020-00-419-8714	6	17
5305-00-116-1469	2	7	3020-00-444-7397	5	8
3020-00-116-3380	7	15	5975-00-462-2911	2	47
1290-00-141-3536	2	18	5355-00-507-9493	1	3
1290-00-141-3538	2	12		2	3
5365-00-143-4591	2	17	5340-00-522-9963	1	4
5355-00-144-7213	1	26		2	4
	2	28	5330-00-527-8900	1	17
5355-00-144-7215	1	29	5330-00-530-4468	1	34
	2	31		2	36
5360-00-151-5969	2	32	5360-00-530-5624	1	30
6240-00-155-7864	1	38		2	32
5365-00-159-0035	2	20	5360-00-530-5974	3	12
5355-00-159-0036	2	8		4	12
5310-00-167-0804	4	17		6	12
5310-00-193-7577	2	2	5365-00-530-7957	2	21
5330-00-202-0812	2	24	5365-00-530-9427	1	35
5355-00-211-8146	2	22		2	37
5310-00-213-4842	2	11	5330-00-531-2364	1	9
3020-00-238-5353	7	7	5310-00-531-9515	5	2
5315-00-253-2828	3	23	1260-00-532-0625	1	49
	4	20	1260-00-534-5698	3	2
5305-00-253-5615	1	36		4	2
	2	52		6	2
1290-00-253-5891	1	23	5355-00-534-5713	1	8
	2	25	5310-00-534-5718	1	27
5305-00-272-3533	6	16		2	29
1240-00-346-8245	3	5	5330-00-534-5719	1	45
	4	5		2	57
	6	5	5360-00-534-5724	3	20
1240-00-346-8246	3	26	1260-00-547-4621	1	10
	4	23		2	11
1240-00-346-8248	1	13	1260-00-547-4623	1	14
	2	15		2	10

NATIONAL STOCK NUMBER AND PART NUMBER INDEX

NATIONAL STOCK NUMBER INDEX					
STOCK NUMBER	FIG.	ITEM	STOCK NUMBER	FIG.	ITEM
1260-00-547-4624	3	1	5310-00-809-5998	5	6
	6	1		7	3
5305-00-550-4238	3	15	5305-00-812-3303	3	18
	4	15	5310-00-835-2036	3	14
5310-00-559-0070	1	42		4	14
5310-00-579-0079	1	39		6	14
	2	40	5315-00-840-0906	7	12
5306-00-582-6893	5	5	5315-00-841-4442	7	13
	7	2	5355-00-850-9799	2	48
5315-00-587-2705	5	7	5305-00-889-2998	2	38
6250-00-620-9551	1	40	5305-00-901-0791	6	8
1290-00-657-8454	1	1	6250-00-921-5003	2	55
3110-00-679-6786	1	28	5905-00-921-6266	2	51
	2	30	5310-00-926-1852	3	16
	2	30		4	16
3020-00-692-1520	3	4	5310-00-934-9747	2	39
	4	4	5330-00-939-0666	2	46
	6	4	5330-00-941-6491	1	21
1260-00-702-8399	1	33	5330-00-948-4036	2	50
1260-00-706-8060	1	25	5310-00-950-1310	5	10
5355-00-706-8064	1	22		7	9
1260-00-706-8069	1	6	5315-00-951-6906	2	13
	2	6	5305-00-958-5474	1	24
1260-00-706-8074	1	16	5305-00-958-6381	1	18
5970-00-708-9292	1	48	5305-00-984-4989	2	44
3110-00-710-4936	7	21	5305-00-984-6191	1	41
5305-00-721-7436	1	32	5305-00-984-6193	1	7
	2	34	5305-00-984-6225	2	43
5305-00-723-9384	3	8	5315-00-995-6912	1	11
	4	8		3	22
5305-00-724-6799	1	5	5355-00-999-6364	2	35
5315-00-739-8927	3	9	3120-01-013-0236	5	13
	4	9	5315-01-048-1727	3	25
	6	9		4	22
1260-00-739-8931	3	19		6	19
1260-00-739-8932	3	21	9905-01-105-5361	2	53
5310-00-740-0429	3	17	9905-01-110-4400	1	37
3020-00-740-0432	3	11	3120-01-112-8010	7	17
	4	11	5305-01-122-9896	6	15
	6	11	3020-01-123-5094	3	21
3020-00-740-0434	3	13	9905-01-124-2503	2	53
	4	13	9905-01-124-2504	2	53
	6	13	1290-01-124-2513	6	22
1260-00-740-0515	3	24	1290-01-124-2514	6	6
	4	21	5365-01-130-2046	7	11
5935-00-772-0498	2	45	5315-01-134-8862	4	3
5365-00-803-7301	3	10		6	3
	4	10	5970-01-144-3097	2	42
	6	10	5306-01-185-3626	2	58
5365-00-807-5335	7	19			

NATIONAL STOCK NUMBER AND PART NUMBER INDEX

FSCM	PART NUMBER	PART NUMBER INDEX	
		STOCK NUMBER	FIG. ITEM
88044	AN4C5		5 1
88044	AN500D-5-3		2 1
88044	AN500D5-3		1 2
88044	AN8C13A	5306-00-582-6893	5 5
			7 2
88044	AN960C416	5310-00-531-9515	5 2
88044	AN960C616	5310-00-167-0804	4 17
80249	BB1538-1	3110-00-710-4936	7 21
96906	MS16562-210	5315-00-840-0906	7 12
96906	MS16562-224	5315-00-841-4442	7 13
96906	MS16562-237	5315-00-058-9784	7 6
96906	MS16562-239	5315-00-587-2705	5 7
96906	MS16562-253	5315-00-058-9808	5 4
			7 1
96906	MS16624-1050	5365-00-803-7301	3 10
			4 10
			6 10
96906	MS16624-1143	5365-00-530-7957	2 21
96906	MS16625-4087	5365-00-807-5335	7 19
96906	MS18063-25	5305-00-407-4122	2 5
96906	MS20068-74	5315-00-044-4258	6 21
96906	MS20068-75	5315-00-253-2828	3 23
			4 20
96906	MS20068-77	5315-01-048-1727	3 25
			4 22
			6 19
96906	MS21083-N6	5310-00-926-1852	4 16
96906	MS21083N6	5310-00-926-1852	3 16
96906	MS21090-352	5305-00-116-1469	2 7
96906	MS21318-21	5305-00-253-5615	1 36
			2 52
96906	MS25236-8623	6240-00-051-4843	2 54
96906	MS27183-18	5310-00-809-5998	5 6
			7 3
96906	MS27183-4	5310-00-950-1310	5 10
			7 9
96906	MS27183-6	5310-00-082-1404	2 41
96906	MS35190-250	5305-00-958-5474	1 24
96906	MS35198-39	5305-00-052-6883	2 26
96906	MS35206-208	5305-00-958-6381	1 18
96906	MS35206-216	5305-00-889-2998	2 38
96906	MS35206-229	5305-00-984-4989	2 44
96906	MS35206-238	5305-00-984-6225	2 43
96906	MS35206-243	5305-00-984-6191	1 41
96906	MS35206-245	5305-00-984-6193	1 7
96906	MS35214-38	5305-00-059-8263	1 46
96906	MS35333-36	5310-00-193-7577	2 2
96906	MS35333-37	5310-00-579-0079	1 39
			2 40
96906	MS35333-38	5310-00-559-0070	1 42
96906	MS35649-262	5310-00-934-9747	2 39

NATIONAL STOCK NUMBER AND PART NUMBER INDEX

FSCM	PART NUMBER	PART NUMBER INDEX	
		STOCK NUMBER	FIG. ITEM
96906	MS35671-17	5315-00-951-6906	2 13
96906	MS35671-36	5315-00-995-6912	1 11
			3 22
96906	MS35691-29	5310-00-835-2036	3 14
			4 14
			6 14
96906	MS35763-404		1 44
96906	MS35764-1004	5306-01-185-3626	2 58
96906	MS35771-69	3120-01-112-8010	7 17
96906	MS35771-90	3120-01-013-0236	5 13
96906	MS51023-49	5305-00-272-3533	6 16
96906	MS51023-64	5305-00-901-0791	6 8
96906	MS51957-12		7 4
96906	MS51957-15	5305-00-054-5649	5 9
			7 8
96906	MS51963-66	5305-00-723-9384	3 8
			4 8
96906	MS51964-51	5305-00-724-6799	1 5
96906	MS52000-3	5330-00-939-0666	2 46
96906	MS91528-0N1B	5355-00-850-9799	2 48
80205	NAS1081-3A4	5305-00-812-3303	3 18
24446	N81P9024C13	5305-00-721-7436	1 32
			2 34
43334	SSR6X3A	3110-00-679-6786	1 28
			2 30
			2 30
81348	W-L-00111/10	6240-00-155-7864	1 38
19200	10545626	3020-00-444-7397	5 8
19207	10905849	5330-00-941-6491	1 21
19200	10933463	5970-01-144-3097	2 42
19207	10933480		2 56
19200	10933488	5905-00-921-6266	2 51
19207	10933489	5330-00-948-4036	2 50
19200	10933490		2 49
19207	10933491	6250-00-921-5003	2 55
19207	10933522	5355-00-999-6364	2 35
19207	11653613	5355-00-144-7213	1 26
			2 28
19207	11653614	5355-00-144-7215	1 29
			2 31
19207	11653615	1290-00-253-5891	1 23
			2 25
19207	11655095	1290-00-100-4144	2 9
19207	11655096	1290-00-100-4145	1 19
			2 23
19207	11655097	5355-00-211-8146	2 22
19207	11655098	1290-00-100-4248	2 19
19207	11655099	1290-00-141-3536	2 18
19207	11655101	5355-00-159-0036	2 8
19207	11655102	5360-00-111-1683	2 16
19207	11655103	1290-00-141-3538	2 12

NATIONAL STOCK NUMBER AND PART NUMBER INDEX

FSCM	PART NUMBER	PART NUMBER INDEX	
		STOCK NUMBER	FIG. ITEM
19207	11655104	5330-00-202-0812	2 24
19207	11655105	5365-00-143-4591	2 17
19207	11655106	5365-00-159-0035	2 20
19207	11655107	5310-00-213-4842	2 11
19207	11676462	3020-01-123-5094	3 21
19200	11747328-1	9905-01-124-2503	2 53
21450	142959	5315-00-014-2959	3 3
19200	505605		3 23
19200	505654		3 25
21450	506202	5940-00-050-6202	1 43
19200	5320625	1260-00-532-0625	1 49
19200	5345698	1260-00-534-5698	2
			4 2
			6 2
19200	5345713	5355-00-534-5713	1 8
19200	5345718	5310-00-534-5718	1 27
			2 29
19200	5345719	5330-00-534-5719	1 45
			2 57
19207	5345720		1 31
			2 33
19200	5345723	5360-00-530-5624	1 30
			2 32
19200	5345724	5360-00-534-5724	3 20
19200	5345922	5330-00-530-4468	1 34
			2 36
19200	5345924	5365-00-530-9427	1 35
			2 37
19200	5383779		1 47
19207	6209551	6250-00-620-9551	1 40
19200	6578454	1290-00-657-8454	1 1
19200	7028399	1260-00-702-8399	1 33
19200	7068048	5340-00-522-9963	1 4
			2 4
19200	7068060	1260-00-706-8060	1 25
			2 27
19200	7068064	5355-00-706-8064	1 22
19200	7068069	1260-00-706-8069	1 6
			2 6
19200	7068070	5330-00-531-2364	1 9
19200	7068071	5355-00-507-9493	1 3
			2 3
19200	7068074	1260-00-706-8074	1 16
19207	7069656	5330-00-527-8900	1 17
19207	7089292	5970-00-708-9292	1 48
19207	7398927	5315-00-739-8927	3 9
			4 9
			6 9
19200	7398931	1260-00-739-8931	3 19
19200	7398932	1260-00-739-8932	3 21
19200	7400426	5305-00-550-4238	3 15

NATIONAL STOCK NUMBER AND PART NUMBER INDEX

FSCM	PART NUMBER	PART NUMBER INDEX	
		STOCK NUMBER	FIG. ITEM
19200	7400426	5305-00-550-4238	4 15
19207	7400429	5310-00-740-0429	3 17
19207	7400430	5360-00-530-5974	3 12
			4 12
			6 12
19207	7400432	3020-00-740-0432	3 11
			4 11
			6 11
19207	7400434	3020-00-740-0434	3 13
			4 13
			6 13
19200	7400515	1260-00-740-0515	3 24
			4 21
19207	7720498	5935-00-772-0498	2 45
19207	7722324	5975-00-462-2911	2 47
19207	7970852	1240-00-346-8246	3 26
			4 23
19200	7970853		3 27
19207	7970855	1240-00-346-8248	1 13
			2 15
19207	7970858	1240-00-346-8249	1 15
19207	7970860	1240-00-346-8250	3 7
			4 7
			6 7
19207	7970862	1260-00-547-4621	1 10
			2 11
19207	7970865	1260-00-547-4623	1 14
			2 10
19207	7970866		1 50
19207	7970867	1240-00-346-8252	1 12
			2 14
19207	7970868	1240-00-346-8253	3 6
			4 6
19207	7970869	1260-00-547-4624	3 1
			4 1
			6 1
19207	7970870	1240-00-346-8245	3 5
			4 5
			6 5
19207	7970873	3020-00-692-1520	3 4
			4 4
			6 4
19200	7972103	9905-01-110-4400	1 37
19204	8437195		7 22
19200	8437912		5 14
19204	8437913	3020-00-409-8783	4 18
19200	8437914		5 12
19204	8437915	1290-00-407-7021	5 11
19204	8437918		5 15
19200	8437920		5 3
19204	8437929	5315-01-134-8862	4 3

SECTION II

TM9-1290-263-34P

(1) ITEM NO	(2) SMR CODE	(3) FSCM	(4) PART NUMBER	(5) DESCRIPTION AND USABLE ON CODE (UOC)	(6) QTY
FIGURE 2, GROUP OO AZIMUTH INDICATOR					
M28E2 10933520-1, 8437917, 8438753					
(PARTIAL VIEW-UPPER SECTION)					
1	PAFZZ	88044	AN500D-5-3	SCREW,MACHINE UOC:F26,324,338	7
2	PAFZZ	96906	MS35333-36	WASHER,LOCK UOC:F26,324,338	11
3	PAFZZ	19200	7068071	DIAL,CONTROL UOC:F26,324,338	1
4	PAFZZ	19200	7068048	CLIP,SPRING TENSION UOC:F26,324,338	1
5	PAFZZ	96906	MS18063-25	SETSCREW UOC:F26,324,338	6
6	PAFZZ	19200	7068069	CLAMP UOC:F26,324,338	1
7	PAFZZ	96906	MS21090-352	SCREW,SELF-LOCKING UOC:F26,324,338	1
8	PAFZZ	19207	11655101	KNOB UOC:F26,324,338	1
9	PAFZZ	19207	11655095	ADJUSTER,INDICATOR UOC:F26,324,338	1
10	PAFZZ	19207	7970865	SPRING UOC:F26,324,338	1
11	PAFZZ	19207	7970862	WASHER UOC:338	1
11	PAFZZ	19207	11655107	WASHER,FLAT UOC:F26,324	1
12	PAFZZ	19207	11655103	SEAT,INDICATOR AZM UOC:F26,324,338	1
13	PAFZZ	96906	MS35671-17	PIN,GROOVED,HEADLES UOC:F26,324,338	1
14	PAFZZ	19207	7970867	CONE,DRILLED UOC:F26,324,338	1
15	PAFZZ	19207	7970855	RE SETTER ASSY UOC:F26,324,338	1
16	PAFZZ	19207	11655102	SPRING,HELICAL,COMP UOC,F26,324,338	1
17	PAFZZ	19207	11655105	RING,CONNECTING,ROU UOC:F26,324,338	1
18	PAFZZ	19207	11655099	BELLOWS,PROTECTION UOC:F26,324,338	1
19	PAFZZ	19207	11655098	RETAINER, INDICATOR UOC:F26,324,338	1
20	PADZZ	19207	11655106	SPACER,RING UOC:F26,324,338	1
21	PAFZZ	96906	MS16624-1143	RING,RETAINING UOC:F26,324,338	1
22	PAFZZ	19207	11655097	WINDOW,DIAL UOC:F26,324,338	1

SECTION II

TM9-1290-263-34P

(1) ITEM NO	(2) SMR CODE	(3) FSCM	(4) PART NUMBER	(5) DESCRIPTION AND USABLE ON CODE (UOC)	(6) QTY
23	PAFZZ	19207	11655096	RING, INDICATOR A21M AZIMUTH UOC: F26, 324, 338	1
24	PAFZZ	19207	11655104	GASKET UOC: F26, 324, 338	1
25	PAFZZ	19207	11653615	POINTER ASSEMBLY UOC: F26, 324, 338	1
26	PAFZZ	96906	MS35198-39	SCREW, MACHINE UOC: F26, 324, 338	4
27	XDFZZ	19200	7068060	FLANGE UOC: F26, 324, 338	1
28	PAFZZ	19207	11653613	POINTER, DIAL UOC: F26, 324, 338	1
29	PAFZZ	19200	5345718	WASHER, SPLIT UOC: F26, 324, 338	1
30	PAFZZ	43334	SSR6X3A	BEARING, BALL, ANNULA ANNULAR UOC: 324, 338	1
30	PAFZZ	43334	SSR6X3A	BEARING, BALL, ANNULA ANNULAR UOC: F26	1
31	PAFZZ	19207	11653614	POINTER, DIAL UOC: F26, 324, 338	1
32	PAFZZ	19200	5345723	SPRING, HELICAL, COMP UOC: F26	1
32	PAFZZ	19204	8447532	SPRING, HELICAL, COMP COMPRESSION UOC: 324, 338	1
33	XBFZZ	19207	5345720	SPACER, SLEEVE UOC: F26, 324, 338	1
34	PAFZZ	24446	N81P9024C13	SCREW, MACHINE UOC: F26, 324, 338	4
35	PAFZZ	19204	8447533	DIAL, SCALE UOC: 324, 338	1
35	PAFZZ	19207	10933522	DIAL, SCALE UOC: F26	1
36	PAFZZ	19200	5345922	FELT, MECHANICAL, PRE UOC: F26, 324, 338	1
37	PAFZZ	19200	5345924	SPACER, RING UOC: F26, 324, 338	1
38	PAFZZ	96906	MS35206-216	SCREW, MACHINE UOC: F26, 324, 338	1
39	PAFZZ	96906	MS35649-262	NUT, PLAIN, HEXAGON UOC: F26, 324, 338	4
40	PAFZZ	96906	MS35333-37	WASHER, LOCK UOC: F26, 324, 338	18
41	PAFZZ	96906	MS27183-6	WASHER, FLAT UOC: F26, 324, 338	4
42	PAFZZ	19200	10933463	INSULATOR, BUSHING UOC: F26, 324, 338	4
43	PAFZZ	96906	MS35206-238	SCREW, MACHINE UOC: F26, 324, 338	2
44	PAFZZ	96906	MS35206-229	SCREW, MACHINE UOC: F26, 324, 338	12
45	PAFZZ	19207	7720498	CONNECTOR, RECEPTACL UOC: F26, 324, 338	1

SECTION II

TM9-1290-263-34P

(1) ITEM NO	(2) SMR CODE	(3) FSCM	(4) PART NUMBER	(5) DESCRIPTION AND USABLE ON CODE (UOC)	(6) QTY
46	PAFZZ	96906	MS52000-3	GASKET UOC:F26,324,338	2
47	PAFZZ	19207	7722324	BOX CONNECTOR,ELECT UOC:F26,324,338	1
48	PAFZZ	96906	MS91528-0N1B	KNOB UOC:F26,324,338	1
49	XBFZZ	19200	10933490	PLATE UOC:F26,324,338	1
50	PAFZZ	19207	10933489	GASKET UOC:F26,324,338	1
51	PAFZZ	19200	10933488	RESISTOR,VARIABLE,W UOC:F26,324,338	1
52	PAFZZ	96906	MS21318-21	SCREW,DRIVE UOC:F26,324,338	4
53	PADZZ	19200	11747328-1	PLATE,IDENTIFICATIO IDENTIFICATION UOC:F26	1
53	PADZZ	19204	8437938	PLATE,IDENTIFICATIO UOC:324	1
53	PADZZ	19204	8438737	PLATE,IDENTIFICATIO IDENTIFICAITON UOC:338	1
54	PAOZZ	96906	MS25236-8623	LAMP,INCANDESCENT UOC:F26,324,338	4
55	PAFZZ	19207	10933491	LAMPHOLDER UOC:F26,324,338	4
56	XADZZ	19207	10933480	HOUSING UOC:F26	1
56	XADZZ	19200	8447291	HOUSING UOC:324,338	1
57	PAFZZ	19200	5345719	GASKET UOC:F26,324,338	1
58	PAFZZ	96906	MS35764-1004	BOLT,SELF-LOCKING UOC:F26,324,338	4

END OF FIGURE

SECTION II

TM9-1290-263-34P

(1) ITEM NO	(2) SMR CODE	(3) FSCM	(4) PART NUMBER	(5) DESCRIPTION AND USABLE ON CODE (UOC)	(6) QTY
FIGURE 3, GROUP 00 AZIMUTH INDICATOR					
M28A1 7970854-1, M28E2 10933520-1					
(PARTIAL VIEW-LOWER SECTION)					
1	PAFZZ	19207	7970869	WASHER UOC:F25,F26	1
2	PAFZZ	19200	5345698	GEAR UOC:F25,F26	1
3	PAFZZ	21450	142959	PIN,GROOVED,HEADLES UOC:F25,F26	1
4	PAFZZ	19207	7970873	GEAR,BEVEL UOC:F25,F26	1
5	PAFZZ	19207	7970870	GEAR ASSY UOC:F25,F26	1
6	PAFZZ	19207	7970868	SHAFT UOC:F25,F26	1
7	PAFZZ	19207	7970860	GEAR ASSY UOC:F25,F26	1
8	PAFZZ	96906	MS51963-66	SETSCREW UOC:F25,F26	1
9	PAFZZ	19207	7398927	PIN,ECCENTRIC UOC:F25,F26	1
10	PAFZZ	96906	MS16624-1050	RING,RETAINING UOC:F25,F26	1
11	PAFZZ	19207	7400432	GEAR,BEVEL UOC:F25,F26	1
12	PAFZZ	19207	7400430	SPRING,HELICAL,COMP COMPRESSION UOC:F25,F26	1
13	PAFZZ	19207	7400434	GEAR,BEVEL UOC:F25,F26	1
14	PAFZZ	96906	MS35691-29	NUT,PLAIN,HEXAGON UOC:F25,F26	2
15	PAFZZ	19200	7400426	SETSCREW UOC:F25,F26	1
16	PAFZZ	96906	MS21083N6	NUT,SELF-LOCKING,HE UOC:F25,F26	1
17	PAFZZ	19207	7400429	WASHER,RECESSED UOC:F25,F26	1
18	PAFZZ	80205	NAS1081-3A4	SETSCREW UOC:F26	1
19	PAFZZ	19200	7398931	GEAR AZIMUTH INDICA UOC:F25,F26	1
20	PAFZZ	19200	5345724	8SPRING,HELICAL,TOR UOC:F25,F26	1
21	PAFZZ	19207	11676462	GEAR,SPUR UOC:F26	1
21	PAFZZ	19200	7398932	GEAR AZIMUTH INDICA UOC:F25	1
22	PAFZZ	96906	MS35671-36	PIN,GROOVED,HEADLES UOC:F25,F26	1

SECTION II

TM9-1290-263-34P

(1) ITEM NO	(2) SMR CODE	(3) FSCM	(4) PART NUMBER	(5) DESCRIPTION AND USABLE ON CODE (UOC)	(6) QTY
23	PAFZZ	96906	MS20068-75	KEY, MACHINE UOC:F26	1
23	XBDZZ	19200	505605	KEY UOC:F25	1
24	PADZZ	19200	7400515	SLEEVE ASY UOC:F25, F26	2
25	PADZZ	96906	MS20068-77	KEY, MACHINE UOC:F26	1
25	XBDZZ	19200	505654	KEY UOC:F25	1
26	PADZZ	19207	7970852	SHAFT ASSEMBLY UOC:F25, F26	1
27	XBDZZ	19200	7970853	BRACKET UOC:F25, F26	1

END OF FIGURE

SECTION II

TM9-1290-263-34P

(1) ITEM NO	(2) SMR CODE	(3) FSCM	(4) PART NUMBER	(5) DESCRIPTION AND USABLE ON CODE (UOC)	(6) QTY
FIGURE 4, GROUP 00 AZIMUTH INDICATOR					
8437917 (PARTIAL VIEW-UPPER SECTION)					
1	XDFZZ	19207	7970869	WASHER UOC:324	1
2	PAFZZ	19200	5345698	GEAR UOC:324	1
3	PAFZZ	19204	8437929	PIN,GROOVED,HEADLES UOC:324	1
4	PAFZZ	19207	7970873	GEAR,BEVEL UOC:324	1
5	PAFZZ	19207	7970870	GEAR ASSY UOC:324	1
6	PAFZZ	19207	7970868	SHAFT UOC:324	1
7	PAFZZ	19207	7970860	GEAR ASSY UOC:324	1
8	PAFZZ	96906	MS51963-66	SETSCREW UOC:324	1
9	PAFZZ	19207	7398927	PIN,ECCENTRIC UOC:324	1
10	PAFZZ	96906	MS16624-1050	RING,RETAINING UOC:324	1
11	PAFZZ	19207	7400432	GEAR,BEVEL UOC:324	1
12	PAFZZ	19207	7400430	SPRING,HELICAL,COMP COMPESSION UOC:324	1
13	PAFZZ	19207	7400434	GEAR,BEVEL UOC:324	1
14	PAFZZ	96906	MS35691-29	NUT,PLAIN,HEXAGON UOC:324	2
15	PAFZZ	19200	7400426	SETSCREW UOC:324	2
16	PAFZZ	96906	MS21083-N6	NUT,SELF-LOCKING,HE UOC:324	1
17	PAFZZ	88044	AN960C616	WASHER,FLAT UOC:324	1
18	PAFZZ	19204	8437913	GEAR,BEVEL UOC:324	1
19	XBDZZ	19200	8438761-1	SHIM UOC:324	1
20	PADZZ	96906	MS20068-75	KEY,MACHINE UOC:324	1
21	PADZZ	19200	7400515	SLEEVE ASY UOC:324	2
22	PADZZ	96906	MS20068-77	KEY,MACHINE UOC:324	1
23	PADZZ	19207	7970852	SHAFT ASSEMBLY UOC:324	1
24	XBDZZ	19200	8447535	BRACKET UOC:324	1

END OF FIGURE

SECTION II

TM9-1290-263-34P

(1) ITEM NO	(2) SMR CODE	(3) FSCM	(4) PART NUMBER	(5) DESCRIPTION AND USABLE ON CODE (UOC)	(6) QTY
FIGURE 5, GROUP 00 AZIMUTH INDICATOR					
8437917 (PARTIAL VIEW-LOWER SECTION)					
1	XBFZZ	88044	AN4C5	BOLT, MACHINE UOC:324	1
2	PAHZZ	88044	AN960C416	WASHER, FLAT UOC:324	1
3	XBDZZ	19200	8437920	COVER UOC:324	1
4	PAFZZ	96906	MS16562-253	PIN, SPRING UOC:324	2
5	PAFZZ	88044	AN8C13A	BOLT, MACHINE UOC:324	4
6	PAFZZ	96906	MS27183-18	WASHER, FLAT UOC:324	4
7	PAFZZ	96906	MS16562-239	PIN, SPRING UOC:324	1
8	PAFZZ	19200	10545626	GEAR, SPUR UOC:324	1
9	PAFZZ	96906	MS51957-15	SCREW, MACHINE UOC:324	3
10	PAFZZ	96906	MS27183-4	WASHER, FLAT UOC:324	3
11	PAFZZ	19204	8437915	RING, RETAINER UOC:324	1
12	XBDZZ	19200	8437914	SHIM UOC:324	1
13	PAFZZ	96906	MS35771-90	BEARING, SLEEVE UOC:324	1
14	XBDZZ	19200	8437912	GEARSHAFT UOC:324	1
15	XBDZZ	19204	8437918	PLATE ASSEMBLY UOC:324	1
END OF FIGURE					

SECTION II

TM9-1290-263-34P

(1) ITEM NO	(2) SMR CODE	(3) FSCM	(4) PART NUMBER	(5) DESCRIPTION AND USABLE ON CODE (UOC)	(6) QTY
FIGURE 6, GROUP 00 AZIMUTH INDICATOR					
8438753 (PARTIAL VIEW-REAR)					
1	PADZZ	19207	7970869	WASHER UOC:338	1
2	PAFZZ	19200	5345698	GEAR UOC:338	1
3	PAFZZ	19204	8437929	PIN,GROOVED,HEADLES UOC:338	1
4	PAFZZ	19207	7970873	GEAR,BEVEL UOC:338	1
5	PAFZZ	19207	7970870	GEAR ASSY UOC:338	1
6	PAFZZ	19200	8438748	SHAFT, SHOULDERED UOC:338	1
7	PAFZZ	19207	7970860	GEAR ASSY UOC:338	1
8	PAFZZ	96906	MS51023-64	SETSCREW UOC:338	1
9	PAFZZ	19207	7398927	PIN,ECCENTRIC UOC:338	1
10	PAFZZ	96906	MS16624-1050	RING,RETAINING UOC:338	1
11	PAFZZ	19207	7400432	GEAR,BEVEL UOC:338	1
12	PAFZZ	19207	7400430	SPRING, HELICAL, COMP COMPRESSION UOC:338	1
13	PAFZZ	19207	7400434	GEAR,BEVEL UOC:338	1
14	PAFZZ	96906	MS35691-29	NUT,PLAIN,HEXAGON UOC:338	2
15	PAFZZ	19204	8438751	SCREW,ADJUSTING UOC:338	2
16	PADZZ	96906	MS51023-49	SETSCREW UOC:338	1
17	PADZZ	19204	8438745	GEAR,BEVEL UOC:338	1
18	XBDZZ	19200	8438761-1	SHIM UOC:338	1
19	PADZZ	96906	MS20068-77	KEY,MACHINE UOC:338	1
20	PADZZ	19204	8438756	SLEEVE ASSEMBLY UOC:338	2
21	PADZZ	96906	MS20068-74	KEY,MACHINE UOC:338	1
22	PADZZ	19200	8438742	SHAFT, SHOULDERED UOC:338	1
23	XBDZZ	19200	8438738	HOUSING UOC:338	1

END OF FIGURE

SECTION II

TM9-1290-263-34P

(1) ITEM NO	(2) SMR CODE	(3) FSCM	(4) PART NUMBER	(5) DESCRIPTION AND USABLE ON CODE (UOC)	(6) QTY
FIGURE 7, GROUP 00 AZIMUTH INDICATOR					
8438753 (PARTIAL VIEW-SIDE)					
1	PAFZZ	96906	MS16562-253	PIN, SPRING UOC:338	2
2	PAFZZ	88044	AN8C13A	BOLT, MACHINE UOC:338	4
3	PAFZZ	96906	MS27183-18	WASHER, FLAT UOC:338	4
4	PAFZZ	96906	MS51957-12	SCREW, MACHINE UOC:338	6
5	XBDZZ	19200	8438752	COVER UOC:338	1
6	PAHZZ	96906	MS16562-237	PIN, SPRING UOC:338	1
7	PAFZZ	19204	8438159	GEAR, SPUR UOC:338	1
8	PAFZZ	96906	MS51957-15	SCREW, MACHINE UOC:338	3
9	PAFZZ	96906	MS27183-4	WASHER, FLAT UOC:338	3
10	PAFZZ	19204	8438755	RING, RETAINER UOC:338	1
11	PAFZZ	19204	8438754	SHIM UOC:338	1
12	PAHZZ	96906	MS16562-210	PIN, SPRING UOC:338	1
13	PAHZZ	96906	MS16562-224	PIN, SPRING UOC:338	2
14	XBDZZ	19200	8438742	SHAFT, SHOULDERED UOC:338	1
15	PAFZZ	19204	8438158	GEAR, WORM UOC:338	1
16	PAFZZ	19204	8438744	GEAR UOC:338	1
17	PADZZ	96906	MS35771-69	BEARING, SLEEVE UOC:338	1
18	XBHZZ	19204	8438747	GEAR, WORM WHEEL UOC:338	1
19	PAFZZ	96906	MS16625-4087	RING, RETAINING UOC:338	1
20	XBDZZ	19200	8438749	SHAFT UOC:338	1
21	PAFZZ	80249	BB1538-1	BEARING, BALL, ANNULA UOC:338	2
22	PAFZZ	19204	8437195	WASHER, SPRING TENSION UOC:338	1
23	XBDZZ	19200	8438741	HOUSING UOC:338	1

END OF FIGURE

SECTION III

TM 9-1290-263-34P

**SPECIAL TOOLS LIST
(NOT APPLICABLE)**



THEN... JOT DOWN THE DOPE ABOUT IT ON THIS FORM, TEAR IT OUT, FOLD IT AND DROP IT IN THE MAIL!

SOMETHING WRONG WITH THIS MANUAL?

FROM: (YOUR UNIT'S COMPLETE ADDRESS)
Your mailing address.

DATE Date you fill out this form.

PUBLICATION NUMBER
TM 9-XXXX-XXX-XX

DATE
Date of TM

TITLE
Title of TM

BE EXACT... PIN-POINT WHERE IT IS

IN THIS SPACE TELL WHAT IS WRONG AND WHAT SHOULD BE DONE ABOUT IT:

PAGE NO.	PARA-GRAPH	FIGURE NO.	TABLE NO.
3		2	
109		51	
2-8			2-1
12	1-6a		

Item 10. Change illustration. Reason: Tube end shown assembled on wrong side of lever cam.

Item 3. The NSN and P/N are not listed on the AMDF nor the MCRL. Request correct NSN and P/N be furnished.

Preventive Maintenance Checks and Services. Item 7 under "Items to be inspected" should be changed to read as follows: Firing linkage and firing mechanism pawl.

Since there are both 20- and 30- round magazines for this rifle, data on both should be listed.

SAMPLE

TEAR ALONG DOTTED LINE

TYPED NAME, GRADE OR TITLE, AND TELEPHONE NUMBER

SIGN HERE:

FILL IN YOUR
UNIT'S ADDRESS



FOLD BACK

DEPARTMENT OF THE ARMY

POSTAGE AND FEES PAID
DEPARTMENT OF THE ARMY

DOD-314

OFFICIAL BUSINESS

PENALTY FOR PRIVATE USE, \$300

Commander
US Army Armament Munitions and Chemical Command
ATTN: AMSMC-MAS
Rock Island, IL 61299-9990

TEAR ALONG DOTTED LINE

FOLD BACK



THEN... JOT DOWN THE DOPE ABOUT IT ON THIS FORM, TEAR IT OUT, FOLD IT AND DROP IT IN THE MAIL!

SOMETHING WRONG WITH THIS MANUAL?

FROM: (YOUR UNIT'S COMPLETE ADDRESS)

DATE

PUBLICATION NUMBER

TM 9-1290-263-34P

DATE

28 Feb 85

TITLE

AZIMUTH INDICATOR M28A1, M28E2, 8437917, 8438753

BE EXACT... PIN-POINT WHERE IT IS

IN THIS SPACE TELL WHAT IS WRONG AND WHAT SHOULD BE DONE ABOUT IT:

PAGE NO.

PARA-GRAPH

FIGURE NO.

TABLE NO.

TEAR ALONG DOTTED LINE

TYPED NAME, GRADE OR TITLE, AND TELEPHONE NUMBER

SIGN HERE:

By Order of the Secretary of the Army:

JOHN A. WICKHAM, JR.
General, United States Army
Chief of Staff

Official:

DONALD J. DELANDRO
Brigadier General, United States Army
The Adjutant General

DISTRIBUTION:

To be distributed in accordance with DA Form 12-40, Direct and General Support Maintenance requirements for Indicator, Azimuth.

WD

THE METRIC SYSTEM AND EQUIVALENTS

LINEAR MEASURE

1 Centimeter = 10 Millimeters = 0.01 Meters = 0.3937 Inches
 1 Meter = 100 Centimeters = 1000 Millimeters = 39.37 Inches
 1 Kilometer = 1000 Meters = 0.621 Miles

SQUARE MEASURE

1 Sq Centimeter = 100 Sq Millimeters = 0.155 Sq Inches
 1 Sq Meter = 10,000 Sq Centimeters = 10.76 Sq Feet
 1 Sq Kilometer = 1,000,000 Sq Meters = 0.386 Sq Miles

WEIGHTS

1 Gram = 0.001 Kilograms = 1000 Milligrams = 0.035 Ounces
 1 Kilogram = 1000 Grams = 2.2 Lb
 1 Metric Ton = 1000 Kilograms = 1 Megagram = 1.1 Short Tons

CUBIC MEASURE

1 Cu Centimeter = 1000 Cu Millimeters = 0.06 Cu Inches
 1 Cu Meter = 1,000,000 Cu Centimeters = 35.31 Cu Feet

LIQUID MEASURE

1 Milliliter = 0.001 Liters = 0.0338 Fluid Ounces
 1 Liter = 1000 Milliliters = 33.82 Fluid Ounces

TEMPERATURE

$5/9 (^{\circ}\text{F} - 32) = ^{\circ}\text{C}$
 212^o Fahrenheit is equivalent to 100^o Celsius
 90^o Fahrenheit is equivalent to 32.2^o Celsius
 32^o Fahrenheit is equivalent to 0^o Celsius
 $9/5 \text{ C}^{\circ} + 32 = \text{F}^{\circ}$

APPROXIMATE CONVERSION FACTORS

<u>TO CHANGE</u>	<u>TO</u>	<u>MULTIPLY BY</u>
Inches	Centimeters	2.540
Feet	Meters	0.305
Yards	Meters	0.914
Miles	Kilometers	1.609
Square Inches	Square Centimeters	6.451
Square Feet	Square Meters	0.093
Square Yards	Square Meters	0.836
Square Miles	Square Kilometers	2.590
Acres	Square Hectometers	0.405
Cubic Feet	Cubic Meters	0.028
Cubic Yards	Cubic Meters	0.765
Fluid Ounces	Milliliters	29.573
Pints	Liters	0.473
Quarts	Liters	0.946
Gallons	Liters	3.785
Ounces	Grams	28.349
Pounds	Kilograms	0.454
Short Tons	Metric Tons	0.907
Pound-Feet	Newton-Meters	1.356
Pounds per Square Inch	Kilopascals	6.895
Miles per Gallon	Kilometers per Liter	0.425
Miles per Hour	Kilometers per Hour	1.609

<u>TO CHANGE</u>	<u>TO</u>	<u>MULTIPLY BY</u>
Centimeters	Inches	0.394
Meters	Feet	3.280
Meters	Yards	1.094
Kilometers	Miles	0.621
Square Centimeters	Square Inches	0.155
Square Meters	Square Feet	10.764
Square Meters	Square Yards	1.196
Square Kilometers	Square Miles	0.386
Square Hectometers	Acres	2.471
Cubic Meters	Cubic Feet	35.315
Cubic Meters	Cubic Yards	1.308
Milliliters	Fluid Ounces	0.034
Liters	Pints	2.113
Liters	Quarts	1.057
Liters	Gallons	0.264
Grams	Ounces	0.035
Kilograms	Pounds	2.205
Metric Tons	Short Tons	1.102
Newton-Meters	Pound-Feet	0.738
Kilopascals	Pounds per Square Inch	0.145
Kilometers per Liter	Miles per Gallon	2.354
Kilometers per Hour	Miles per Hour	0.621

